

INVESTIGATIONS ON AN 8-PATH ULTRASONIC METER – WHAT SENSITIVITY TO UPSTREAM DISTURBANCES REMAIN?

MR. JOHN LANSING, SICK | Maihak, Houston, Texas
DR. VOLKER HERRMANN, SICK | Maihak, Dresden, Germany
MR. TORALF DIETZ, SICK | Maihak, Dresden, Germany
MR. STEVE CALDWELL, CEESI, Nunn, Colorado

1. ABSTRACT

During the past several years the use of ultrasonic meters (USMs) has gained world-wide acceptance for fiscal applications. The many benefits of USMs have been documented in several papers at virtually every major conference. As the cost of gas continues to rise, the benefits of accurate measurement become even more important. For this reason many users are installing flow conditioners in an attempt to create the same profile as the meter was subjected to during flow calibration. The newest release of AGA Report No. 9 [Ref. 1] has a section that discusses a recommended installation for the USM which includes a flow conditioner. However, in many applications, using a flow conditioner is not preferred due to the increased piping length, added differential pressure, and higher installed cost.

This paper will discuss testing an 8-path ultrasonic meter to identify what uncertainties remain from installation effects. Data on installations with and without a flow conditioner, including corresponding accuracy results, will be presented. This data helps identify the magnitude of uncertainties that may be present in field installations, and thus may help the user make a decision as to whether or not a flow conditioner is required.

2. INTRODUCTION

Two years ago Colorado Engineering Experimental Station, Inc. (CEESI) performed installation effects testing on a chordal design USM for a customer at their Ventura flow calibration facility in Garner, Iowa [Ref 2]. The purpose of this testing was to identify what installation effects would still remain after placing various combinations of elbows and one tee upstream of the meter. The testing was conducted on a 300 mm (12 inch) Schedule 40 meter operating at approximately 72 Bar (1040 psig). The results of the installation effects were published at the 2004 CEESI USM Conference in Estes Park, Colorado [Ref 2].

Several tests were conducted and it was shown that one of the configurations created more flow profile distortion, and thus more impact on the meter's accuracy, than the others. Since this configuration resulted in more extreme distortion than typical field installations, it was decided to use this piping configuration in the development of this paper.

The meter used for this testing was an 8-path chordal design meter. This meter essentially has a design similar to the British Gas (BG) design meters. A thorough description of this meter, and its use as a working standard, was presented at the 2006 ISFFM [Ref 3]. Conventional BG meters have transducers that are configured in an X pattern. As all the transducers associated in this 4-path meter design are in a vertical plane (parallel with each other), this makes it easy to incorporate a second independent set of sensors on the other side (see Figure 1 for more details). This meter also uses the same chordal path location and weighting as the traditional BG meter. The design incorporates a reduced bore compared to the pipeline velocity. For consistency all results discussed in this paper are meter velocity which is slightly higher than the actual pipeline velocity.

Figure 1 is an artist drawing of this design. Two independent Signal Processing Units (SPU) were used, one for each diagonal of the X design configuration. For this paper Meter Electronics A will refer to the electronics associated with one 4-pair group of transducers, and Meter Electronics B will be associated with the second 4-pair group of transducers.

This paper presents installation results on an 8-path meter with several upstream piping configurations after the installation affects piping. These include 20D with a CPA, 20D with no flow conditioner, 10D with no flow conditioner, and 5D with a PTB flow conditioner.

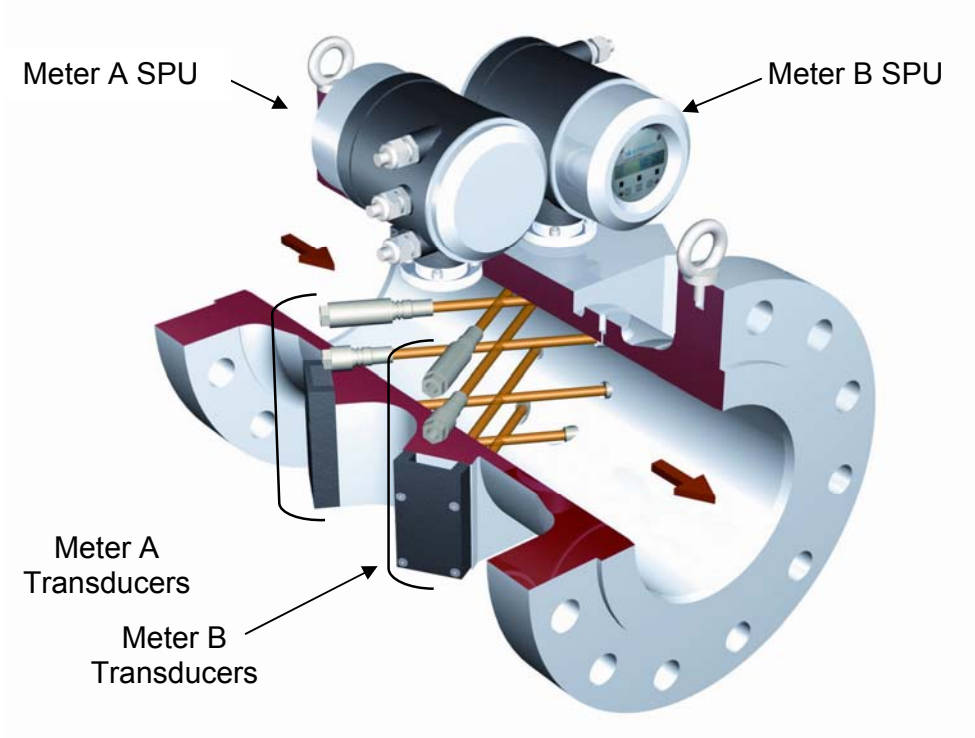

Figure 1: 8-Path Meter Used for Testing



Figure 2: 8-Path Meter – Body

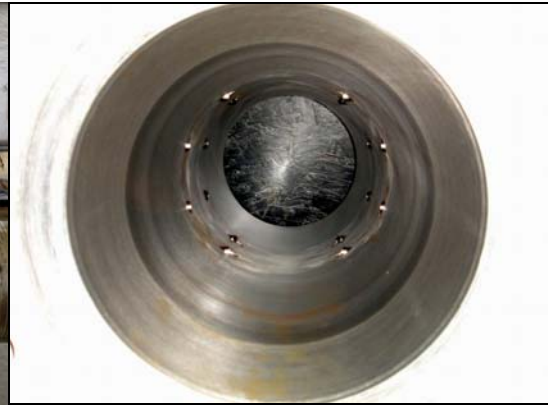

Figure 3: 8-Path Meter – Transducers

Figure 2 is a picture of the 8-Path meter installed in baseline piping. Note the two sets of electronics installed on the top of the meter. Two pressure transmitters were used to help reduce uncertainty. Figure 3 shows the inside of the meter body. All transducers are visible, and from this picture we can see the orientation is symmetrical from top to bottom, and also from Meter A to Meter B. In this design there are no bouncing signals, only direct line-of-sight communication between the sensors.

3. THE PIPING LAYOUT

3.1 Piping Configuration for Baseline Testing

To evaluate the impact of installation effects, the meter was initially installed and tested in a straight run of pipe. The test assembly consisted of 10D of pipe, a CPA 50E flow conditioner and another 10D of pipe between the flow conditioner and the meter. There was also a significant length of straight pipe upstream of this assembly, although larger diameter, that produced a very symmetrical, non-swirling gas profile.

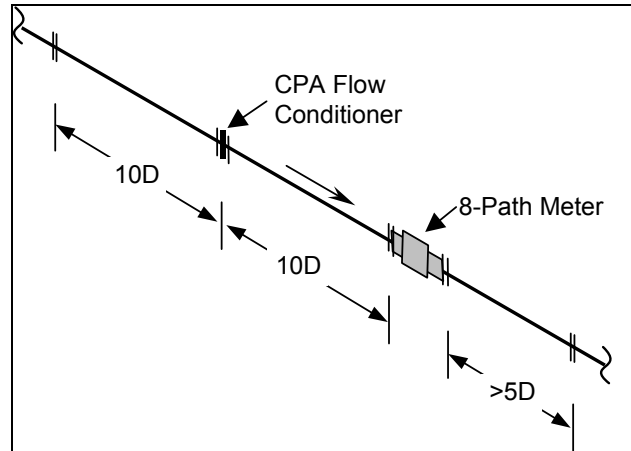

Figure 4: Meter Run Assembly for Baseline Testing

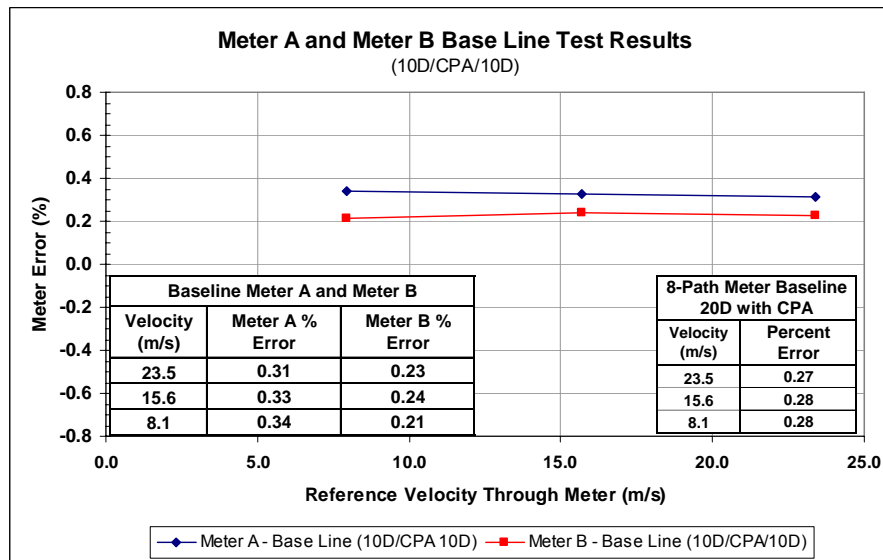

Figure 5: Baseline Test Results

Figure 5 shows the baseline results of both electronics under ideal conditions. The results show that both meter electronics (and associated transducers) were within about 0.15% of each other under ideal profile conditions. The average 8-Path unadjusted error was 0.28% as shown in the table within Figure 5. The 8-path errors were computed by averaging the results of each of the meter electronics.

This meter was also tested by the manufacturer at atmospheric conditions. The FWME results of the "as found" tests were within 0.1% of that shown in Figure 5. However, the meter was not adjusted by the manufacturer. The initial testing was to help validate the atmospheric test would agree with the high pressure calibration work performed by CEESI.

3.2 Effect of Flow Conditioner Blockage

During the construction phase of a typical meter station, and its' associated piping in the real world, some construction materials (including wood, paper and other debris) may have inadvertently been left in the piping. When the meter station is put into service, the velocity of the flowing gas may move the material down the pipe until it becomes lodged against a fitting or other obstruction. Frequently this ends up being the flow conditioner upstream of the meter.

Users have often asked questions about the impact on accuracy of such blockage of the flow conditioner. With little data published, a test was conducted in 2004 and published at the CEESI USM Conference [Ref 4] and also at the 2005 NSFMW Conference [Ref 5]. To assess the impact of a significant obstruction in front of the flow conditioner, the previous test condition was duplicated (simulating a potential field type of blockage) by placing duct tape over approximately 40% of the flow conditioner. Figure 6 shows the blocked flow conditioner prior to testing. The blockage was installed at the bottom of the pipe.



Figure 6: Blocked Flow Conditioner Used for Test

This type of a blockage creates a distorted profile with little or no swirl. This effect can be seen in the velocity ratios of the 4 paths on Meters A and B shown in Figure 7 and 8. As can be seen the profile is shifted towards the bottom of the meter. This is due to the gas being pulled into the low pressure zone created by the blockage on the lower portion of the flow conditioner.

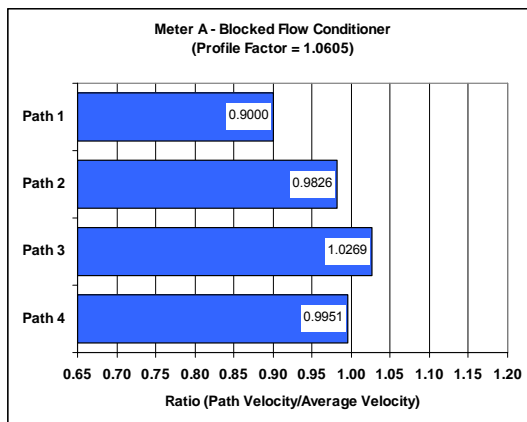

Figure 7: Meter A – Velocity Ratios with Blocked Flow Conditioner

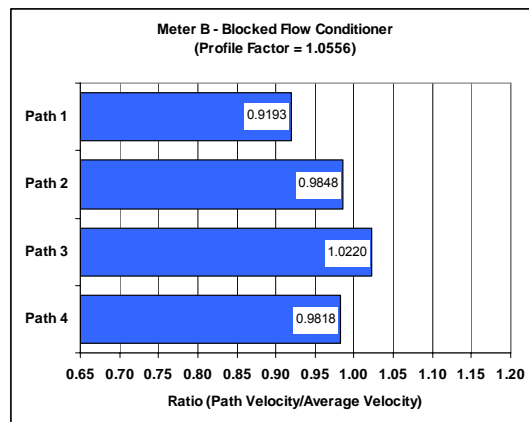

Figure 8: Meter B – Velocity Ratios with Blocked Flow Conditioner

Although the profile is quite distorted, the impact on the meter accuracy is minimal, as shown in Figure 9. Over the range of velocities tested, each of the meters shifted by less than 0.2%.

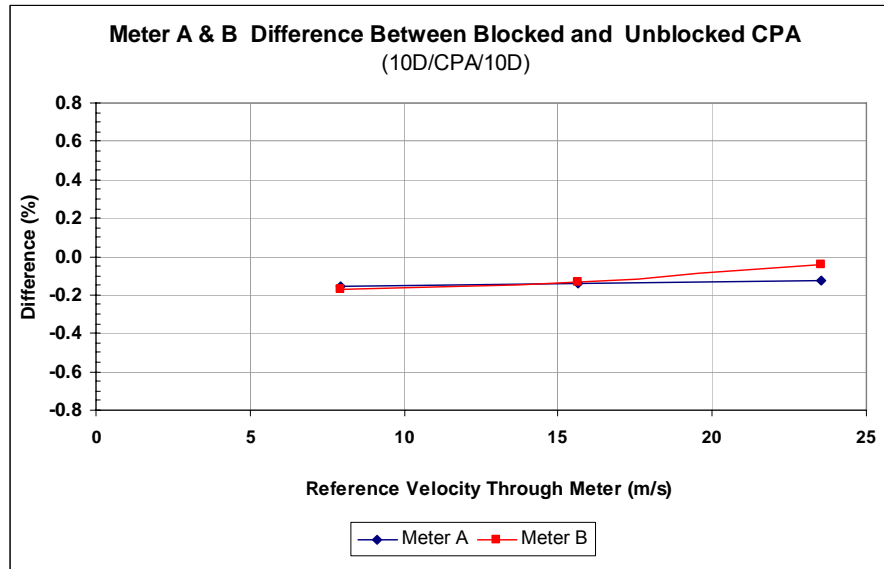

Figure 9: Meter Error – Blocked Conditioner vs. Baseline

Figure 9 shows the results of each set of electronics (Meter A and Meter B). This graph represents the difference between the baseline (unblocked) and the blocked CPA for each of the individual electronics. To assess the true impact of an 8-path meter, both results (baseline and blockage) were externally averaged to produce a graph which represents the net impact on all 8 paths. Graphical results of this are shown in Figure 10 along with a table summarizing the percent difference between the baseline 8-path meter data and the blocked CPA flow conditioner data.

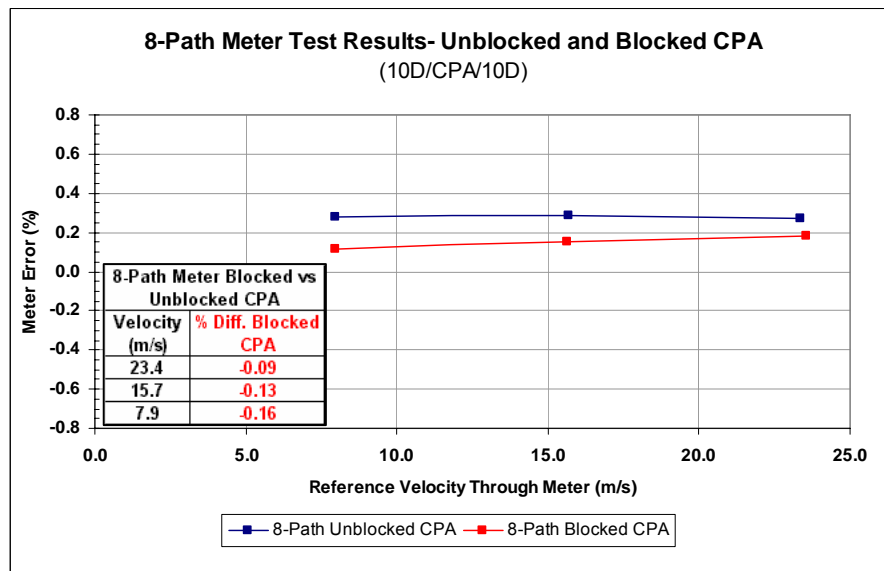

Figure 10: Meter Error – 8-Path Results

As is shown in the table within Figure 10, the impact on this blockage is on the order of -0.13%. Therefore, the distorted profile, as show in Figures 7 & 8, had little impact on the meter's accuracy.

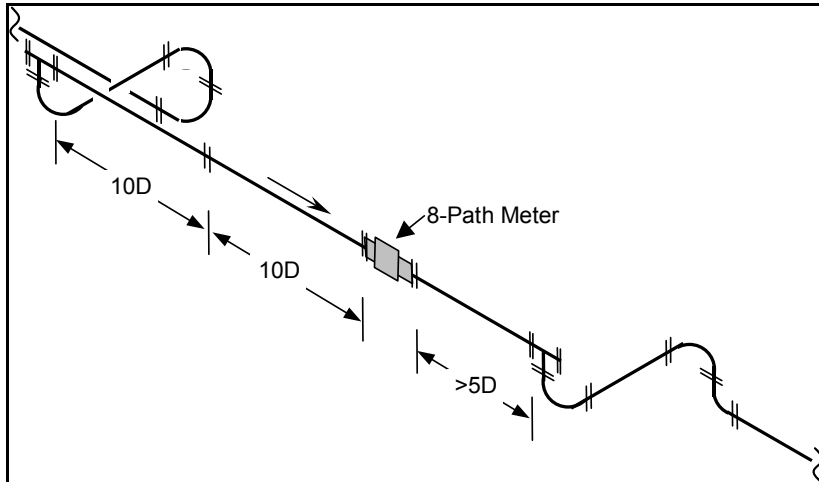

Figure 13: 20D – No Flow Conditioner Test Run Assembly

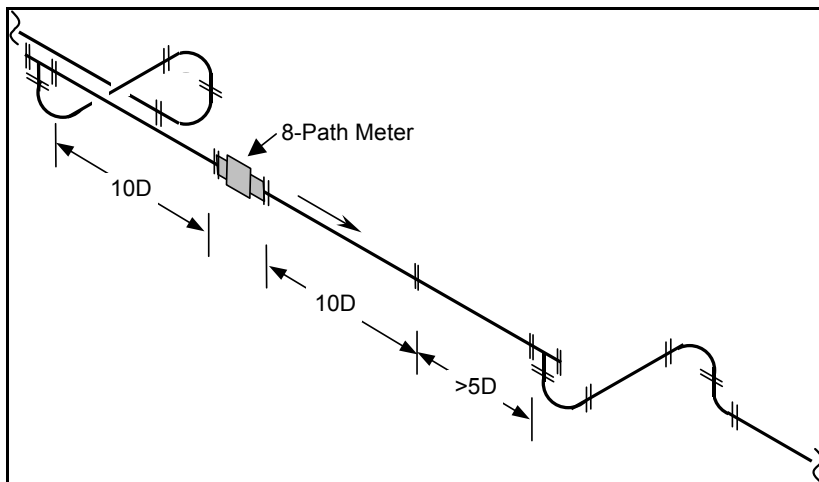

Figure 14: 10D – No Flow Conditioner Test Run Assembly

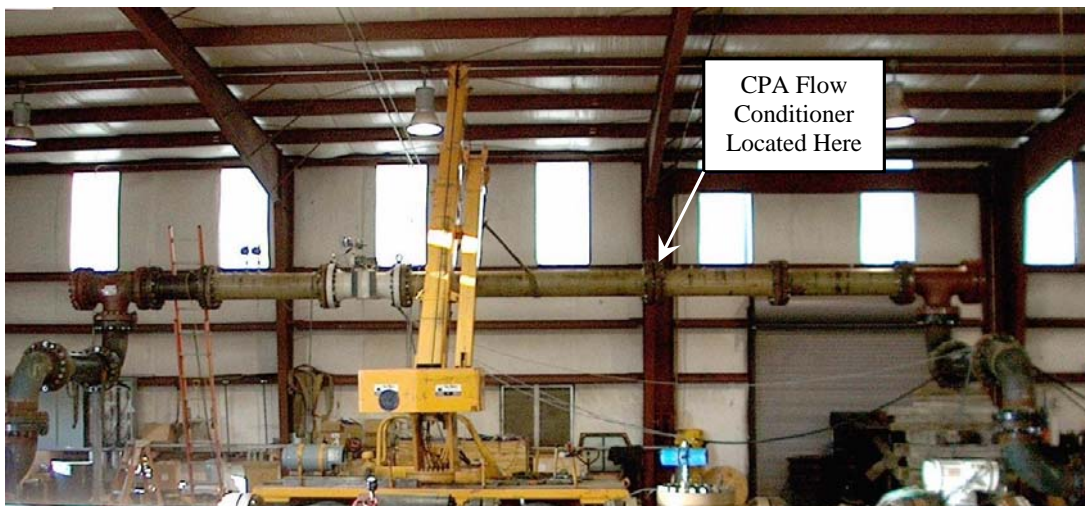

Figure 15: Picture of 10D/CPA/10D Installation

The results of the testing, in terms of velocity ratio and profile factor are shown in Figures 16 and 17 (following). This data was used to develop graphs throughout this paper.

METER A	Meter Velocity (m/s)	Velocity Ratios				Profile Factor
		Path 1	Path 2	Path 3	Path 4	
Base Line, 10D/CPA/10D	23.38	0.915	1.020	1.020	0.913	1.116
	15.67	0.914	1.019	1.020	0.916	1.115
	7.94	0.915	1.018	1.019	0.919	1.111
Elbows/Tee, 10D/CPA/10D	23.37	0.892	1.014	1.027	0.935	1.117
	15.60	0.892	1.011	1.028	0.937	1.115
	7.98	0.897	1.011	1.027	0.935	1.112
Elbows/Tee 20D/No CPA	23.40	1.067	1.061	0.960	0.804	1.080
	15.71	1.061	1.057	0.964	0.808	1.082
	8.05	1.065	1.060	0.964	0.799	1.086
Elbows/Tee 10D/No CPA	23.40	1.100	1.062	0.952	0.783	1.070
	15.78	1.103	1.062	0.950	0.787	1.064
	7.85	1.102	1.062	0.951	0.785	1.068

Figure 16: Meter A Velocity Ratios and Profile Factors

METER B	Meter Velocity (m/s)	Velocity Ratios				Profile Factor
		Path 1	Path 2	Path 3	Path 4	
Base Line, 10D/CPA/10D	23.38	0.917	1.019	1.020	0.913	1.114
	15.67	0.914	1.019	1.020	0.916	1.114
	7.94	0.914	1.018	1.021	0.917	1.114
Elbows/Tee, 10D/CPA/10D	23.37	0.925	1.022	1.017	0.905	1.114
	15.60	0.927	1.022	1.016	0.905	1.113
	7.98	0.923	1.022	1.016	0.908	1.113
Elbows/Tee 20D/No CPA	23.40	0.801	0.963	1.061	1.063	1.086
	15.71	0.801	0.966	1.060	1.056	1.091
	8.05	0.804	0.966	1.058	1.061	1.085
Elbows/Tee 10D/No CPA	23.41	0.780	0.954	1.065	1.093	1.079
	15.78	0.786	0.955	1.066	1.084	1.080
	7.86	0.779	0.955	1.067	1.088	1.084

Figure 17: Meter B Velocity Ratios and Profile Factors

From Figure 16 and 17 it can be seen that for the 10D/CPA/10D assembly there was virtually no difference in the flow profile between the baseline test with straight upstream piping, and the test with the elbows and tee upstream. There was, however, a slightly more biased profile as can be seen from the velocity ratios in the following figures. Graphical results of both meters path ratios, comparing the baseline to the 10D/CPA/10D, are shown in Figures 18 & 19.

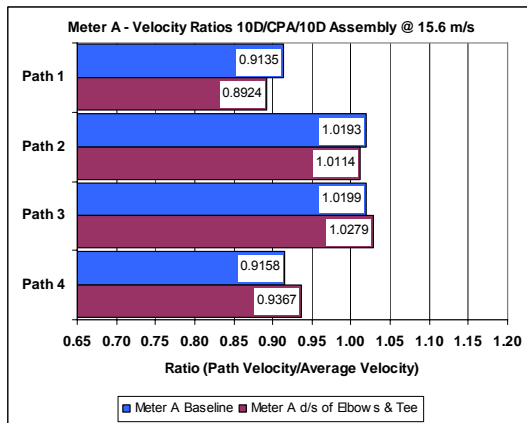

Figure 18: Meter A Velocity Ratios – Baseline vs. Disturbed Flow

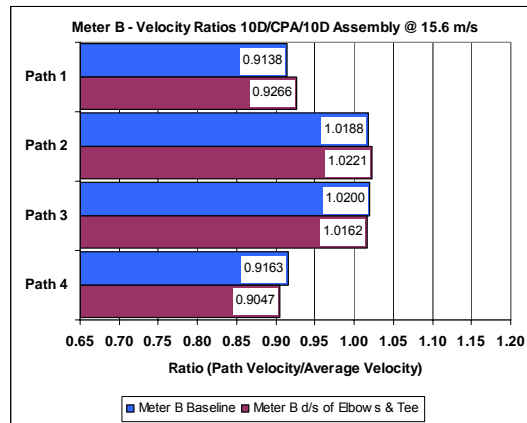

Figure 19: Meter A Velocity Ratios – Baseline vs. Disturbed Flow

Figure 18 shows the path ratio results of Meter A for both the baseline in blue vs. the installation effects in red. Although there are some differences, they are typical of what could be seen in the field. Figure 19 shows the results of Meter B for the same condition. Note that the differences by path from baseline to installation effect are reversed. That is Meter A Path 1 ratio differences are reversed when compared to Meter B. This is also true for Path 4 ratios for both meters. The middle two paths are very close in both electronics, but do show the same trend. This effect is due to a small amount of residual swirl still present after the flow conditioner.

Figure 20 represents the performance of the 8-path meter baseline compared to the installation effect with the tee and elbow combination (10D/CPA/10D) as shown in Figures 12 & 15. The table with Figure 20 summarizes the differences which work out to an average of about 0.055%.

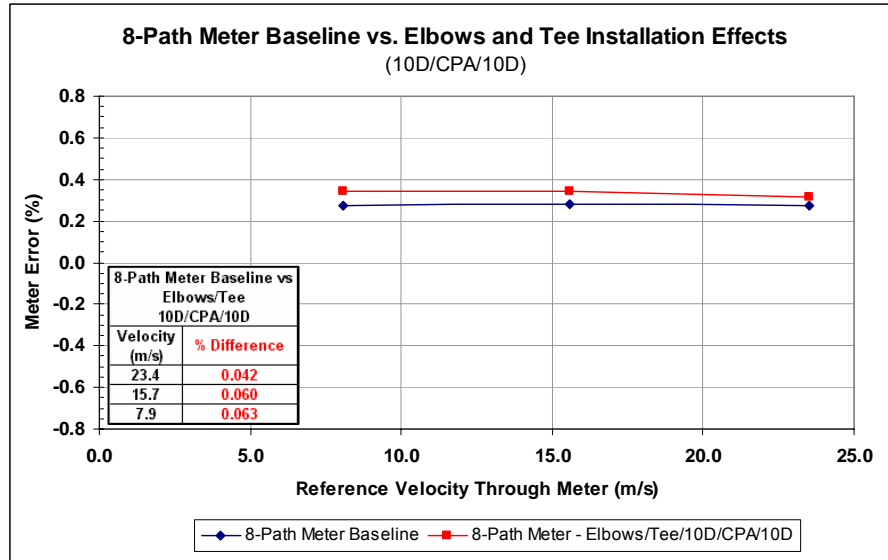

Figure 20: 8-Path Meter Performance with Tee and Elbows, 10D/CPA/10D

The next test conducted was with the same 20D of upstream piping in front of the meter, as shown in Figure 13, but with this time there was no CPA flow conditioner. The velocity ratios, as shown in Figure 21 and 22, indicate a significantly distorted profile due to the meter now seeing the effects of the high amount of swirl caused by the upstream piping.

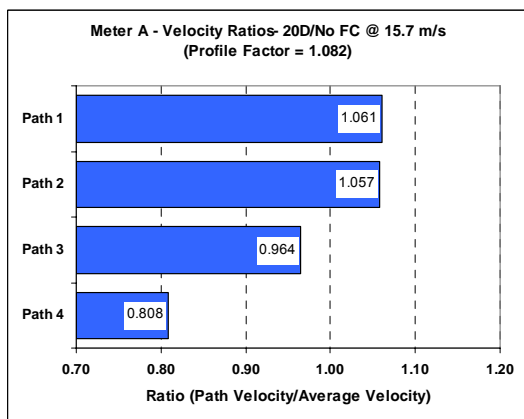

Figure 21: Meter A Profile for 20D – No CPA

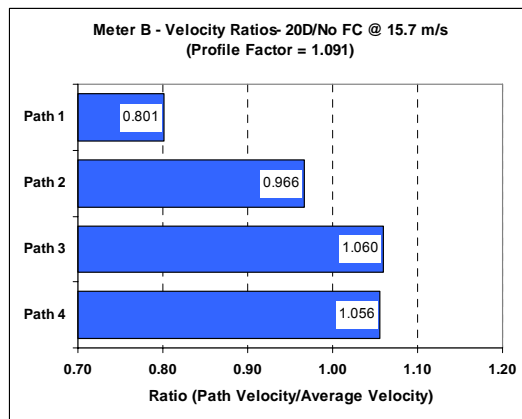

Figure 22: Meter B Profile for 20D – No CPA

Due to the swirl, and the fact that the paths for Meter A are diagonally opposite to those of Meter B, the path velocity ratios are almost the inverse of each other.

Figure 23 shows the impact on the accuracy of the Meter A electronics and Figure 24 show the results for Meter B. Here we see that both electronics registered slightly slower than the baseline (somewhere on average around -0.15 to -0.2%). Both shifted in the same direction (slightly slower compared to the baseline).

Figure 25 shows the results of the 8-path when both are averaged together. Since the bias for both Meter A and Meter B were similar, the net result is not much different than for the individual meter electronics. The inserted table shows the net affect to be on the order of -0.15%.

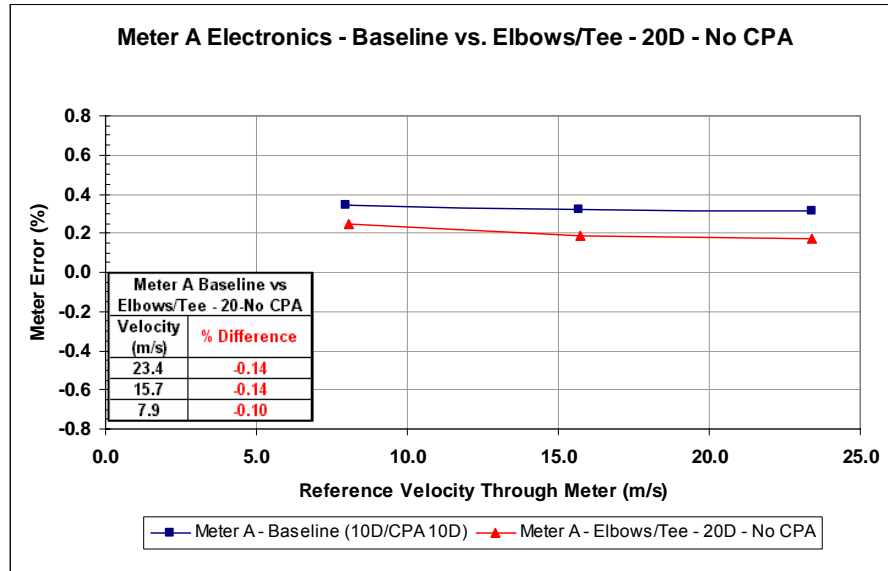

Figure 23: Meter A Results – 20D No CPA

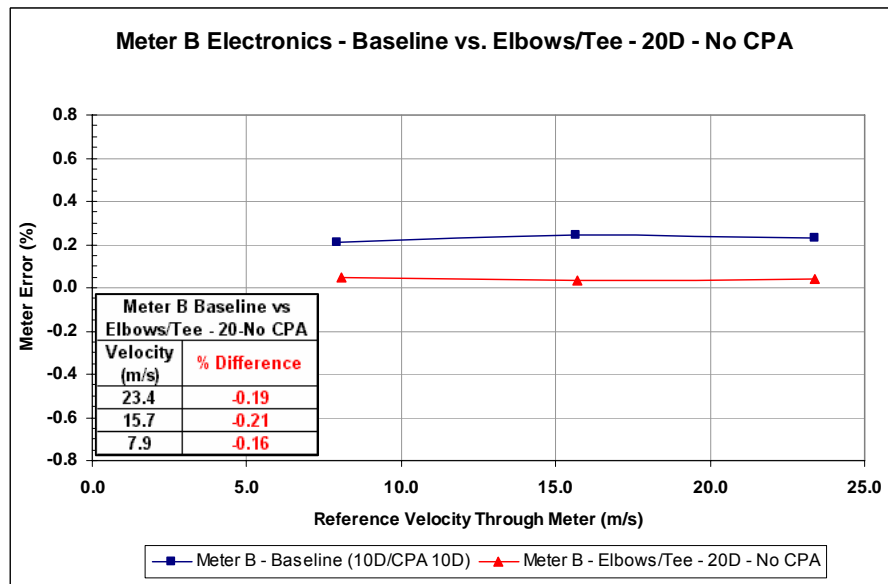

Figure 24: Meter B Results – 20D No CPA

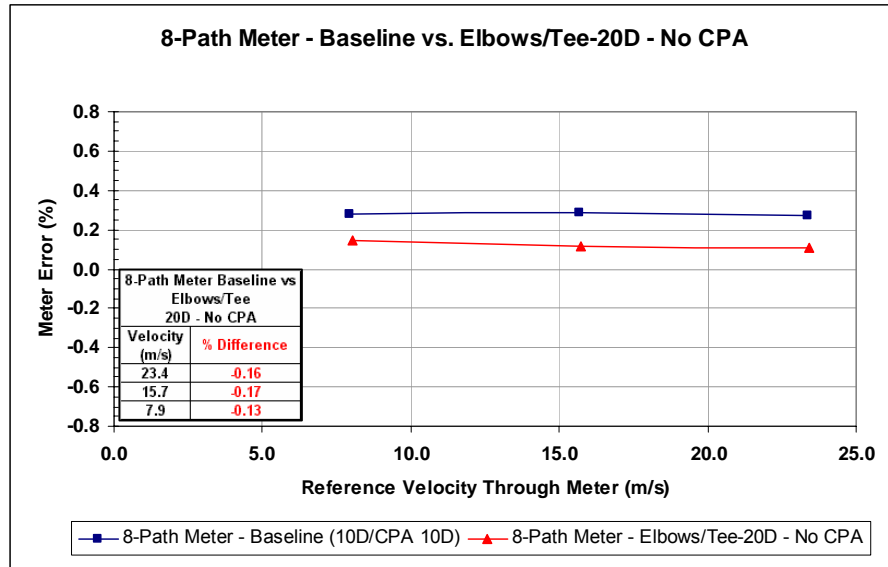

Figure 25: 8-path Meter Results – 20D No CPA

The next test was to move the meter from 20D to 10D downstream of the tee. Again this testing was performed with no flow conditioner. Figure 26 is a picture that shows this installation with the meter at 10D (also see drawing in Figure 14). In this picture the meter is located upside down. Later in the paper this will be discussed in further detail. The initial testing was performed with the electronics located upward.



Figure 26: 8-path Meter at 10D No Flow Conditioner

The following three figures show the results of Meter A, Meter B and the 8-Path meter results from installation at 10D and no flow conditioner. The 8-Path results were the average of each of the meter's results.

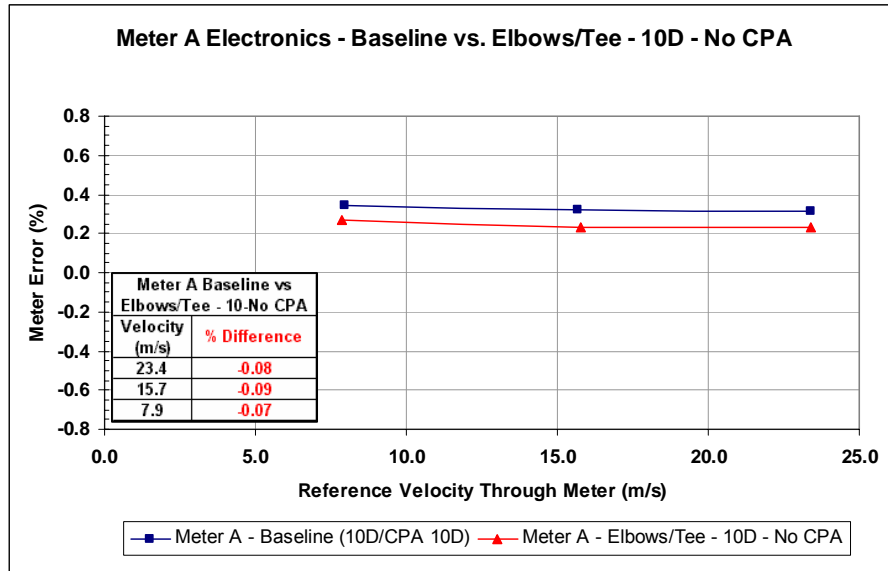

Figure 27: Meter A at 10D No Flow Conditioner

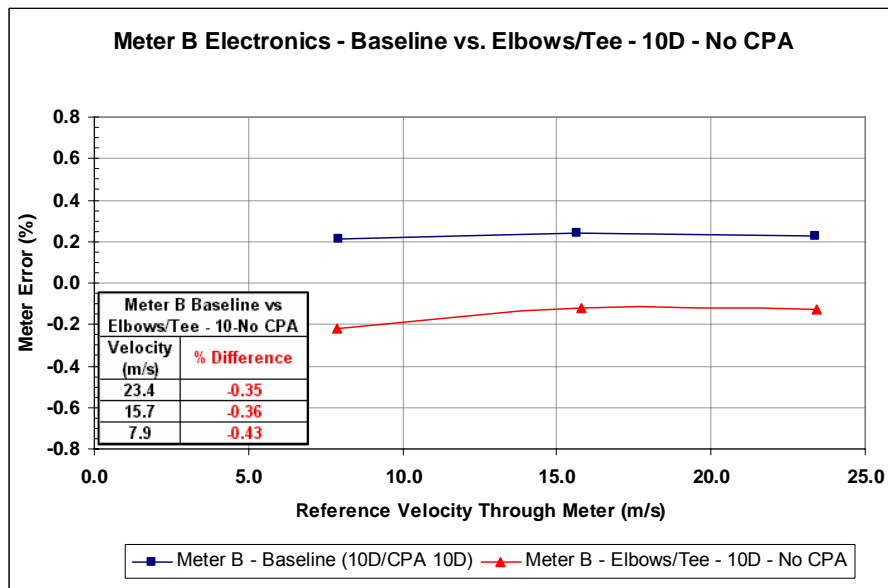

Figure 28: Meter B at 10D No Flow Conditioner

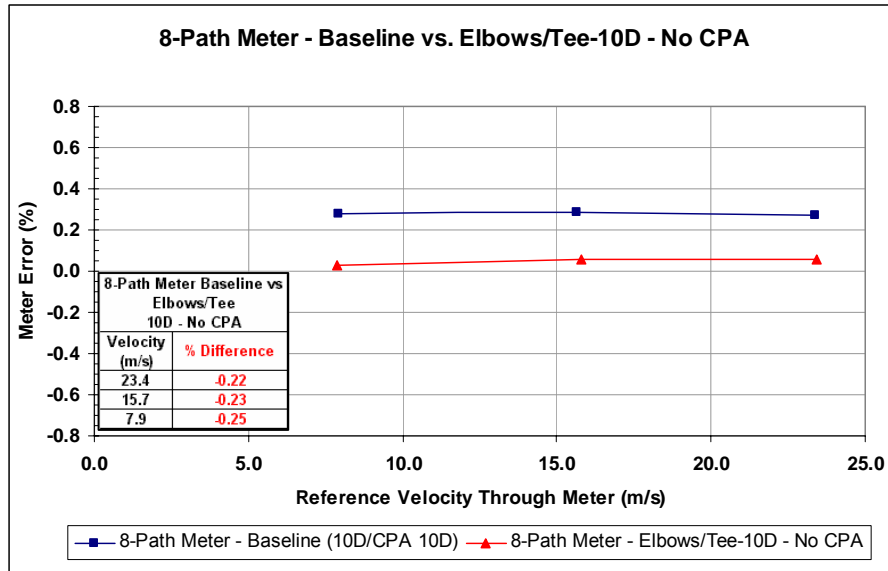

Figure 29: 8-Path Meter at 10D No Flow Conditioner

In reviewing the results of both Meter A and Meter B results, it is apparent that there is a more significant difference than was shown at 20D with no flow conditioner. Meter A was relatively unaffected where Meter B exhibited more affect. Averaging the two to produce the 8-Path results shows that the impact on accuracy is only on the order of -0.23% on average.

Figures 30 and 31 show the distorted velocity profiles produced by this combination of elbows and tee. Once again we see an extremely distorted profile, with Meter B being virtually the inverse of Meter A. This is due the significant amount of swirl which is caused by the series of elbows and the tee being out of plane.

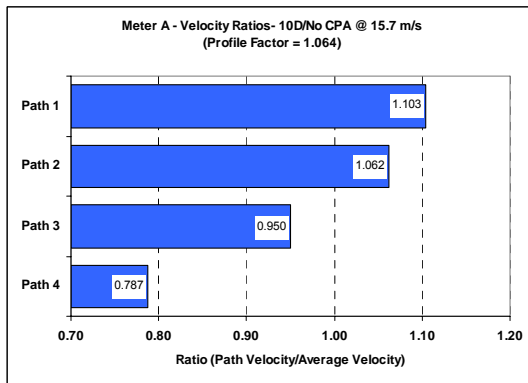

Figure 30: Meter A Profile at 10D – No CPA

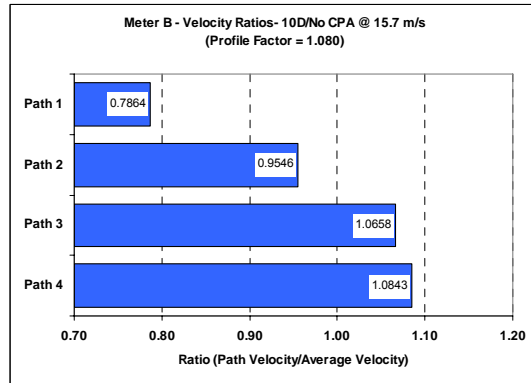

Figure 31: Meter B Profile at 10D – No CPA

By reviewing the profiles at 20D and 10D with no flow conditioner, it is apparent the distortion caused by the swirl in the pipeline has increased. The difference between Path 1 and 4, when the meter was located in the 20D configuration, showed approximately 26% difference in velocity. At 10D the difference increased to about 32%, indicating significantly more swirl. The important thing to remember is the profile shown in Figure 30 and 31 is what the CPA flow conditioner was presented with. The profile after the CPA, as seen by the meter 10D downstream, had very little distortion. This can be seen by comparing Figures 30 and 31 with Figures 18 and 19.

3.4 Additional Meter Testing

To further investigate why Meter A's response was close to baseline, but Meter B's was more affected, additional testing was performed at the CEESI Calibration Facility approximately 2 months later (September 2006). The photo in Figure 26 was taken during the time of the additional testing.

This second series of tests was also conducted only at 10D with no flow conditioner. However, for these tests, the meter was not only tested straight up, as was done in all the previous testing, but now rotated at 90 degree intervals to provide data from four different orientations. From this data it was hoped to gain a better understanding of why the highly distorted profile provided some differences between Meter A and Meter B.

Since the flow profile is 3-dimensional, the radial orientation of the meter may have an impact on the meters' performance. To test this theory, the meter was installed in its normal position, as it had been before, and then rotated 90°, 180° and 270°. The meter was again tested at the three velocities in each position. Figure 32 and 33 are tables that show the velocity ratios and flow profiles for each of these meters, and for each of the four positions.

METER A	Meter Velocity m/s	Velocity Ratios				Profile Factor
		Path 1	Path 2	Path 3	Path 4	
Elbows/Tee 10D/No CPA (Normal Orientation)	23.5	1.094	1.063	0.952	0.791	1.069
	15.6	1.099	1.065	0.951	0.783	1.071
	8.1	1.097	1.062	0.951	0.791	1.067
Elbows/Tee 10D/No CPA (Rotated 90°)	23.6	1.088	1.075	0.952	0.768	1.093
	15.6	1.088	1.073	0.952	0.771	1.089
	8.0	1.087	1.074	0.953	0.770	1.092
Elbows/Tee 10D/No CPA (Rotated 180°)	23.4	1.089	1.064	0.954	0.789	1.074
	15.8	1.086	1.065	0.954	0.788	1.077
	7.9	1.087	1.065	0.955	0.786	1.079
Elbows/Tee 10D/No CPA (Rotated 270°)	23.5	1.086	1.052	0.955	0.815	1.056
	15.6	1.086	1.053	0.955	0.813	1.057
	8.0	1.085	1.055	0.955	0.809	1.061

Figure 32: Meter A Velocity Ratios and Profile Ratios As a Function of Radial Orientation

METER B	Meter Velocity m/s	Velocity Ratios				Profile Factor
		Path 1	Path 2	Path 3	Path 4	
Elbows/Tee 10D/No CPA (Normal Orientation)	23.5	0.786	0.956	1.065	1.084	1.080
	15.6	0.779	0.954	1.068	1.087	1.084
	8.1	0.781	0.955	1.069	1.084	1.085
Elbows/Tee 10D/No CPA (Rotated 90°)	23.6	0.781	0.955	1.069	1.084	1.085
	15.6	0.810	0.956	1.054	1.083	1.062
	8.0	0.808	0.956	1.055	1.084	1.063
Elbows/Tee 10D/No CPA (Rotated 180°)	23.4	0.785	0.952	1.064	1.097	1.071
	15.8	0.784	0.954	1.063	1.093	1.075
	7.9	0.786	0.955	1.063	1.092	1.074
Elbows/Tee 10D/No CPA (Rotated 270°)	23.5	0.769	0.953	1.075	1.087	1.092
	15.6	0.766	0.953	1.075	1.088	1.094
	8.0	0.766	0.952	1.076	1.088	1.094

Figure 33: Meter B Velocity Ratios and Profile Ratios As a Function of Radial Orientation

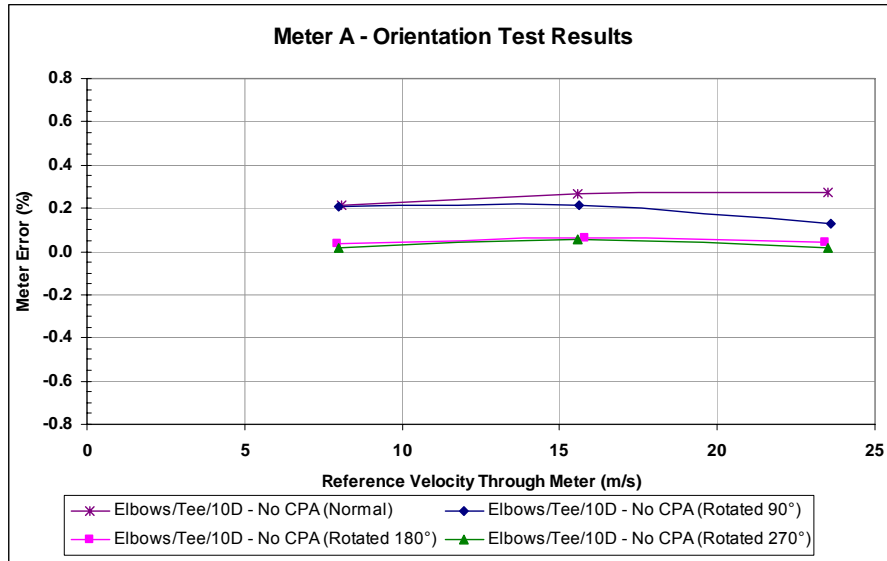

Figure 34: Meter A Error As a Function of Radial Orientation

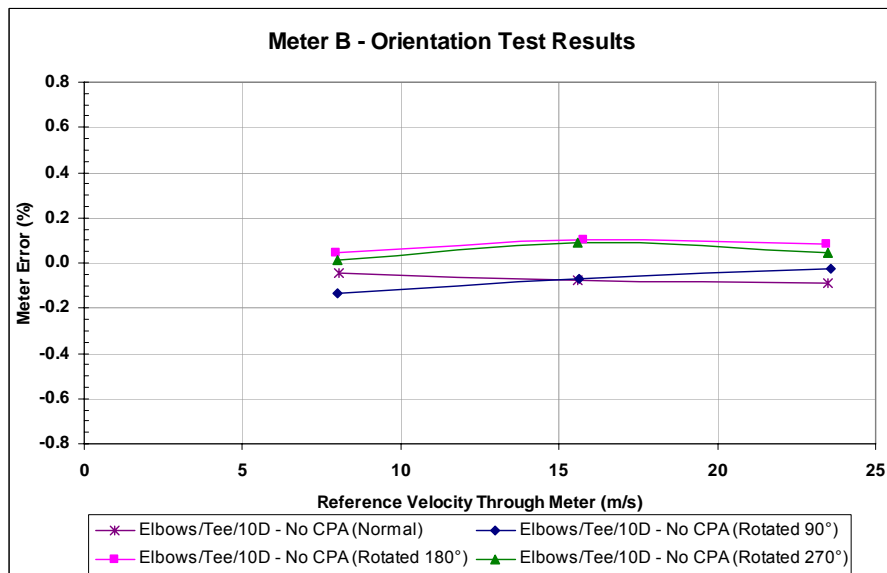

Figure 35: Meter B Error As a Function of Radial Orientation

These results show two distinct performance results depending upon orientation. These results were combined to produce the results of the 8-path meter and are shown in Figure 36.

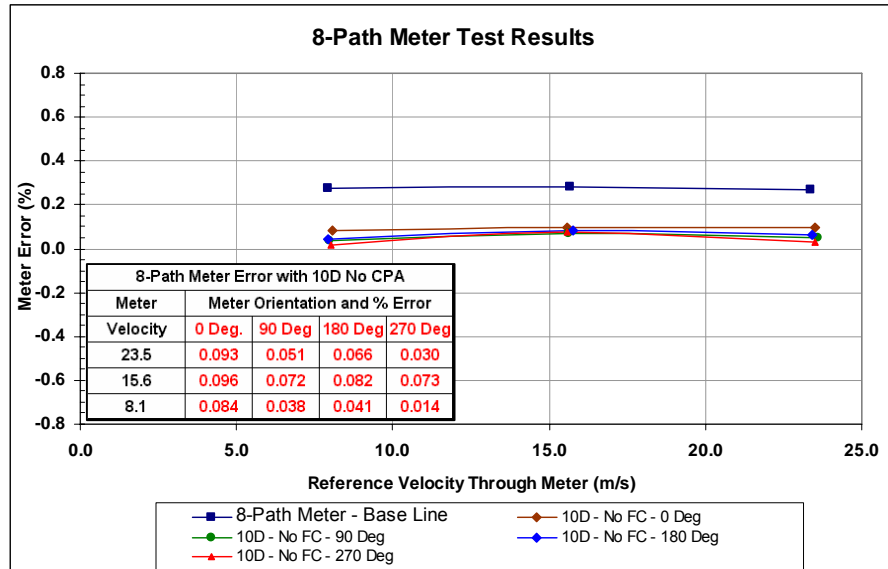

Figure 36: 8-Path Meter Error As a Function of Radial Orientation

Figures 34 and 35 represent error curves for each of the meter electronics. The net shift from the severely distorted profile was on the order of -0.2% from baseline. This installation created much more severe profile distortion and swirl than a typical piping installation. Thus one would expect the performance of the 8-path meter in a typical field installation to be better than this.

Figure 36 shows the baseline error of the 8-path meter, and then the meter error for each of the individual 8-path meter orientations. From these graphs it can be seen that for both meters the deviation did not change by more than about 0.04% due to the radial orientation of the meter. This would be considered scatter and is not a significant.

Meter	Meter Orientation and % Difference			
Velocity	0 Deg.	90 Deg	180 Deg	270 Deg
23.5	-0.177	-0.219	-0.205	-0.241
15.6	-0.187	-0.212	-0.202	-0.210
8.1	-0.193	-0.238	-0.236	-0.263
Average	-0.186	-0.223	-0.214	-0.238

Figure 37: 8-Path Meter Percent Difference from Baseline as a Function of Meter Orientation

Figure 37 shows the error of the installation effect relative to the baseline of the meter. As can be seen the error was on the order of -0.2% relative to the baseline of the meter.

4. 5D INSTALLATIONS WITH A PTB FLOW CONDITIONER

Often times there is not sufficient space to permit installation of 10D of upstream piping in front of a USM. These include offshore platforms and applications where a USM is replacing other existing measurement technologies. With this short space (5D) measurement uncertainty can be higher if no flow conditioner is used when compared to 10D.

One solution is to use a PTB flow conditioner which is located 2D from the meter, and with 3D upstream, for a total installed upstream length of only 5D. This flow conditioner has 421 small holes that permit installation much closer to a meter than traditional flow conditioners. Figure 38 is a picture of this device.



Figure 38: PTB Flow Conditioner

The PTB flow conditioner was also tested with the same elbow and tee combination discussed earlier in this paper. Figure 39 is a drawing of this flow conditioner at the time of testing. Figure 40 is a picture of the PTB taken at the time of testing.

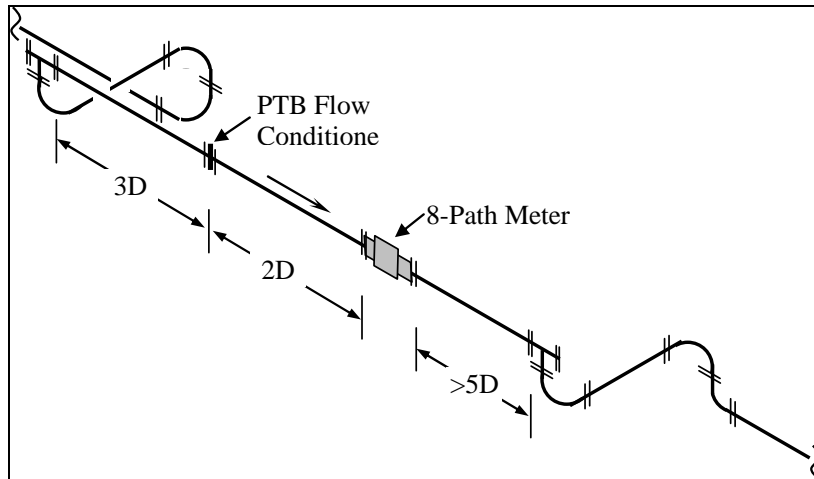

Figure 39: 3D/PTB/2D Flow Conditioner Piping



Figure 40: 8-Path Meter with PTB Flow Conditioner Piping

The PTB was tested at the same velocities as all other meter configurations presented in this paper. The differential pressure transmitter was installed to validate the pressure drop was comparable to other flow conditioners.

The results of the baseline test with the PTB and the 8-path meter vs. the installation effects are presented in Figure 41.

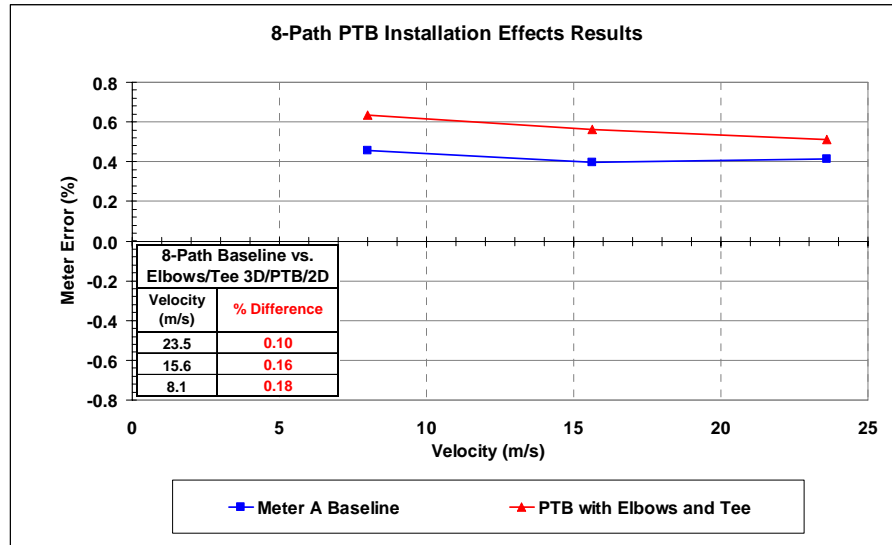

Figure 41: PTB Flow Conditioner Downstream of Elbows and Tee

Figure 41 shows the 8-path meter baseline with the PTB flow conditioner and with the elbows and tees. This shows the 8-path meter provides results that are well within the uncertainty budgets of PTB and ISO, and also well within AGA 9 requirements. The table within Figure 41 shows the installation affect was only on the order of +0.15%. For close coupled applications, where space does not permit installation of 10D of straight pipe, the PTB conditioner will provide results that are comparable to 10D with no flow conditioner. The penalty of using a flow conditioner is the added differential pressure and installation costs.

5. CONCLUSIONS

Today the cost of energy is higher than it was several years ago, and it is not likely this trend will reverse itself anytime soon. Different world areas may have different philosophies on how to install and operate an ultrasonic meter. The most recent release of AGA 9 (October 2006) now recommends the use of flow calibration when using a USM for fiscal measurement, and also recommends the use of a flow conditioner. However, it stops short of saying it is required, just that the manufacturer must provide the user with installation requirements that will permit the meter to remain within 0.3% of the baseline calibration after installation in the field.

This paper presented results on testing an 8-path design USM with and without a flow conditioner. A variety of piping conditions were previously tested [Ref 2] and the most severe case was chosen to be duplicated for this paper. Besides presenting information on the affect this upstream piping disturbance had on the meter's accuracy, data was published on what the impact might be with some blockage in front of the flow conditioner. Since the flow conditioner may act like a filter for large debris, several papers have been published showing the affect on a meter under these conditions [Ref 2 & 5]. However, many world areas do not embrace the use of a flow conditioner as it adds pressure drop and overall length to the measurement package.

When a flow conditioner is not used, a traditional length of upstream pipe recommended by USM manufacturers has been 10D. In these cases it is likely the profile entering the meter may be more distorted and have some level of swirl.

The data presented for this 8-path meter was from an installation that created a high degree of swirl and asymmetrical flow entering the meter. This could be considered a “worst case” scenario as most installations do not employ two out-of-plane elbows prior to the meter piping. The results of this test showed the following:

1. The 8-path meter at 10D, with no flow conditioner, showed results to be within 0.2% of the baseline, and thus meets all metrology requirements,
2. The 8-path meter was repeatable within 0.04 at 10D, with no flow conditioner, regardless of meter orientation,
3. Using an 8-path meter does reduce uncertainty when the installation includes a flow conditioner,
4. Using 5D with a PTB flow conditioner upstream of the 8-path meter showed it easily meets all metrology requirements,
5. And an 8-path meter provides significantly improved performance when severely distorted, swirling flow profiles exist.

Today the cost of accuracy has never been more important. There are many applications where space does not permit using 20D of straight pipe in conjunction with a flow conditioner. For these installations the 8-path meter design, with 10D of straight pipe, provides an alternative solution that meets or exceeds metrology requirements such as PTB, ISO and AGA 9. For applications that do not permit 10D due to space requirements, the use of 5D and a PTB flow conditioner will also meet metrology requirements. Through continued research it may be possible one day to reduce the uncertainty of an ultrasonic meter station to an even lower level than presented here.

6. REFERENCES

1. AGA Report No. 9, *Measurement of Gas by Multipath Ultrasonic Meters*, October 2006, American Gas Association, 1515 Wilson Boulevard, Arlington, VA 22209
2. Larry Garner & Joel Clancy, *Ultrasonic Meter Performance – Flow Calibration Results – CEESI Iowa – Inspection Tees vs. Elbows*, CEESI Ultrasonic Conference, June 2004, Estes Park, CO
3. Dr. Volker Herrmann, Dr. Matthias Wehmeier, Toralf Dietz, Dr. Rainer Kramer, Dr. Bodo Mickan, *A New Low Pressure Calibration Facility Using 8-Path Ultrasonic meters As Working Standards*, May 2006, Queretaro, Mexico
4. John Lansing, *USM Advanced Diagnostics*, CEESI Ultrasonic Conference, June 2005, Estes Park, CO
5. John Lansing, *How Today's USM Diagnostics Solve Metering Problems*, North Sea Flow Measurement Conference, October 2004, Tonsberg, Norway